

GENERAL NOTE:  
CONTRACTOR TO ASSUME RESPONSIBILITY FOR CONCRETE TESTING THROUGHOUT CONSTRUCTION.

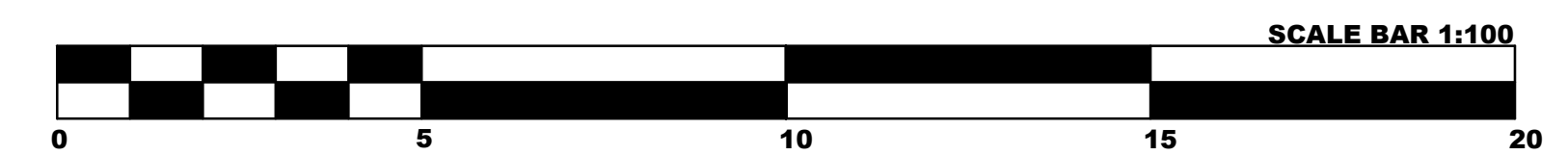

02		
01	25/03/2026	ISSUED FOR TENDER
No.	DATE	DESCRIPTION

Revisions:

Client:  
TOWN OF HARTLAND

Project:  
HARTLAND BOAT LAUNCH UPGRADES

Drawing Title:  
PLAN-STRUCTURAL

This drawing is the exclusive property of GLENN GROUP LTD and must be returned upon request. Reproduction in part or in whole is forbidden without the designer's permission.

Do not scale drawings.

The Contractor and all Sub-contractors shall verify all job site dimensions, all drawings, details & specifications. The contractor shall report any discrepancies, in writing, to GLENN GROUP LTD, prior to commencing with any work.

Date:	03.04.2026
Drawn By:	YUN
Project No.:	2508
DWG NO.:	
Checked By:	DLH
Scale:	

MINIMUM THICKNESS OF 150 MM TO PROVIDE 75 MM OF COVER TO SINGLE-LAYER REINFORCING STEEL. WHERE DUAL-LAYER REINFORCEMENT IS REQUIRED (SLAB THICKNESS 250 MM OR GREATER), MINIMUM THICKNESS SHALL BE 210 MM TO PROVIDE 75 MM COVER TO BOTH LAYERS WITH 25 MM CLEAR SPACING BETWEEN LAYERS.

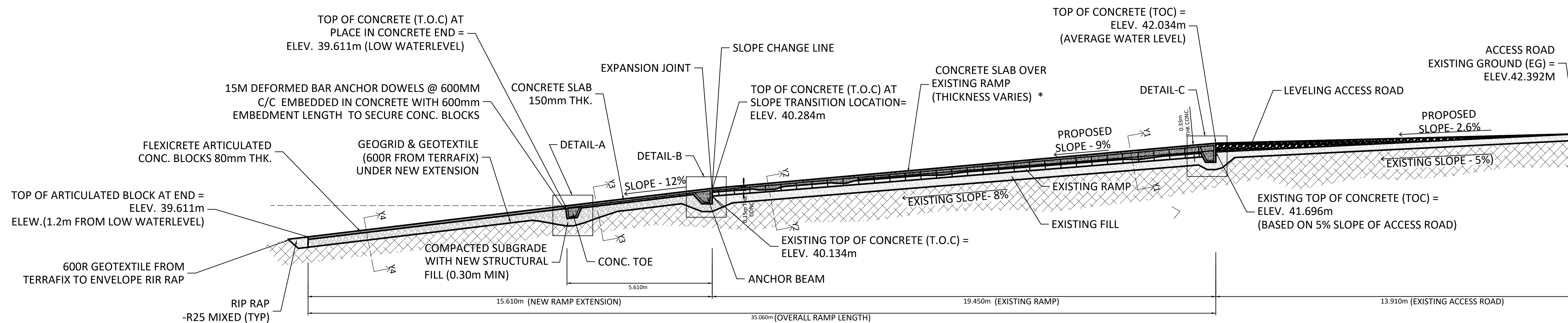

**SECTION X-X**  
SCALE 1:75

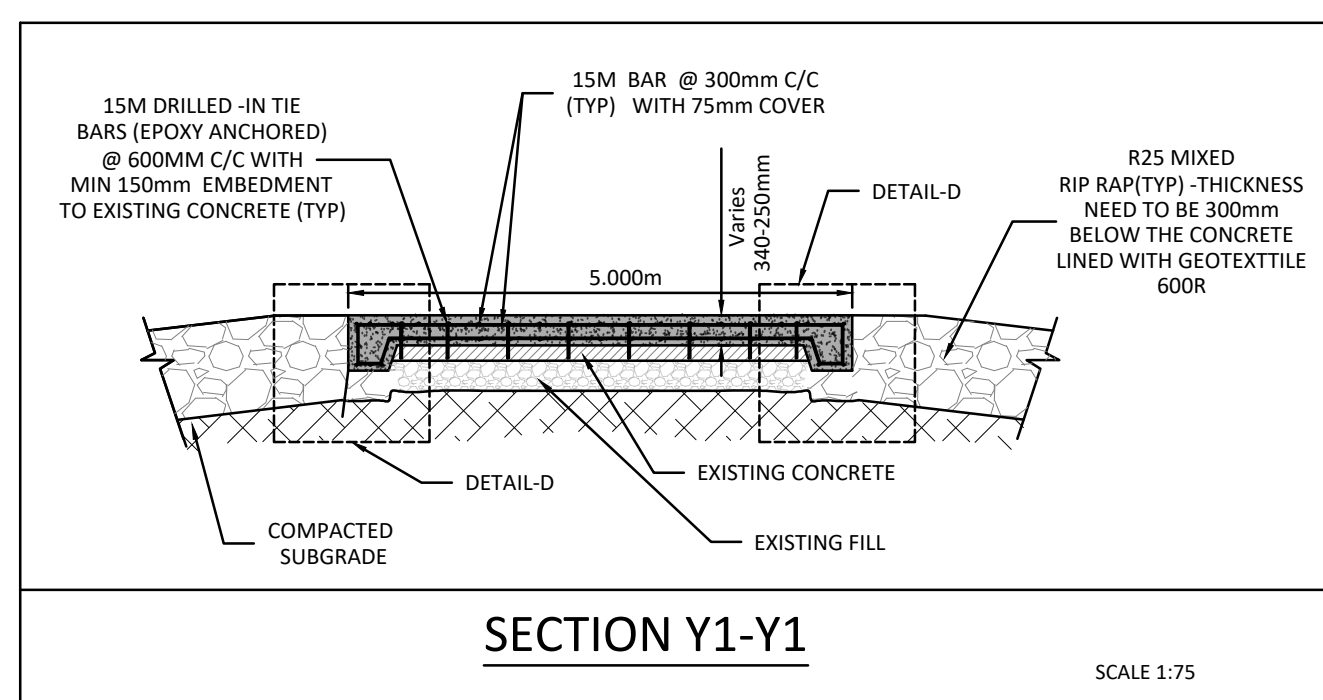

**SECTION Y1-Y1**

SCALE 1:75

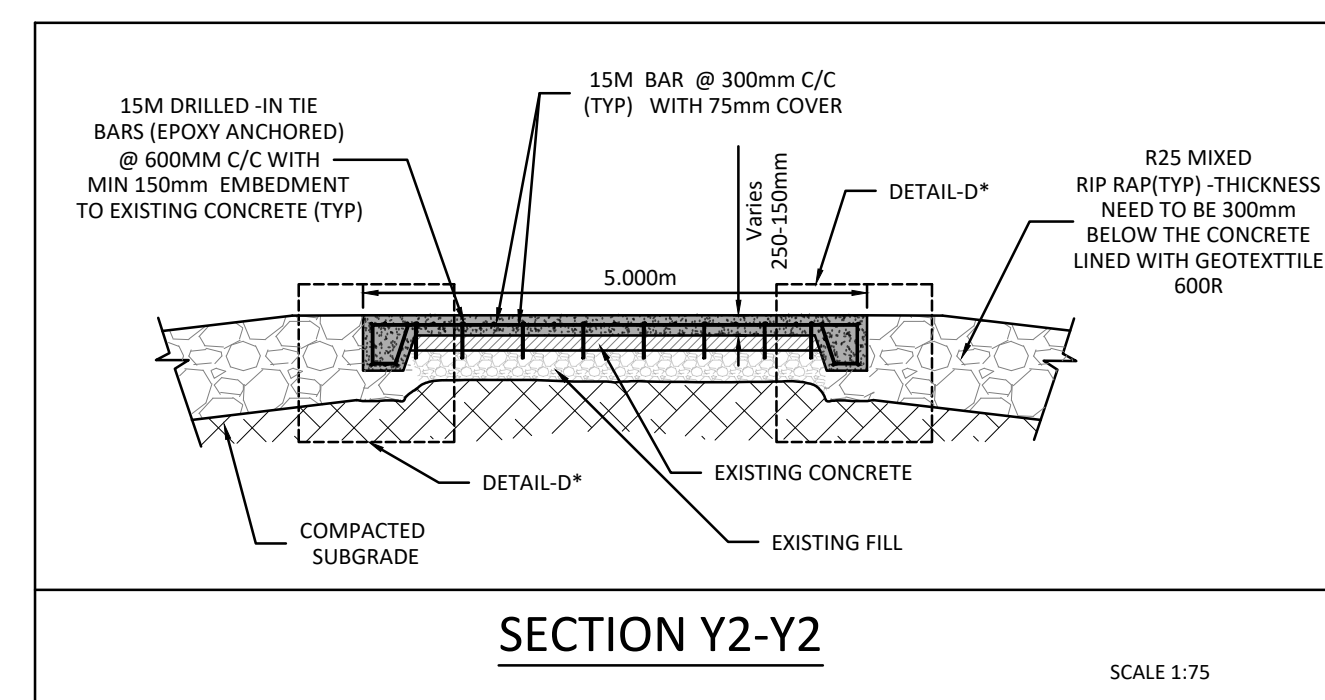

**SECTION Y2-Y2**

SCALE 1:75

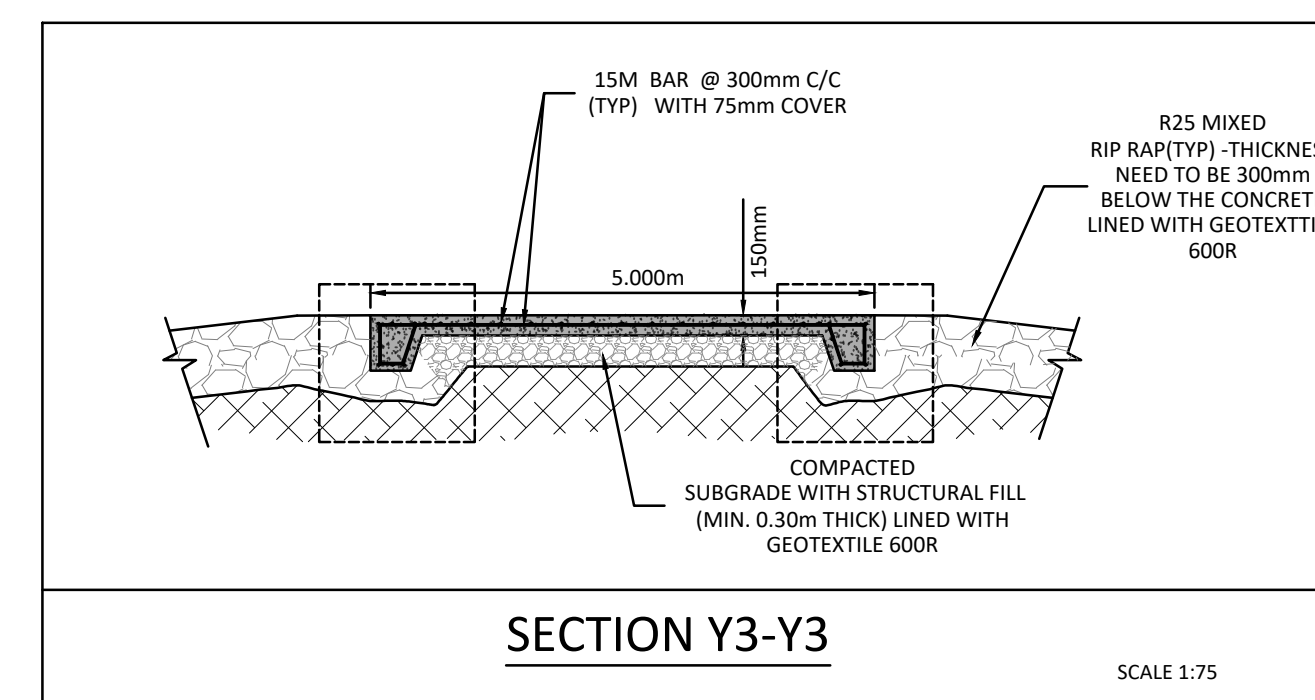

**SECTION Y3-Y3**

SCALE 1:75

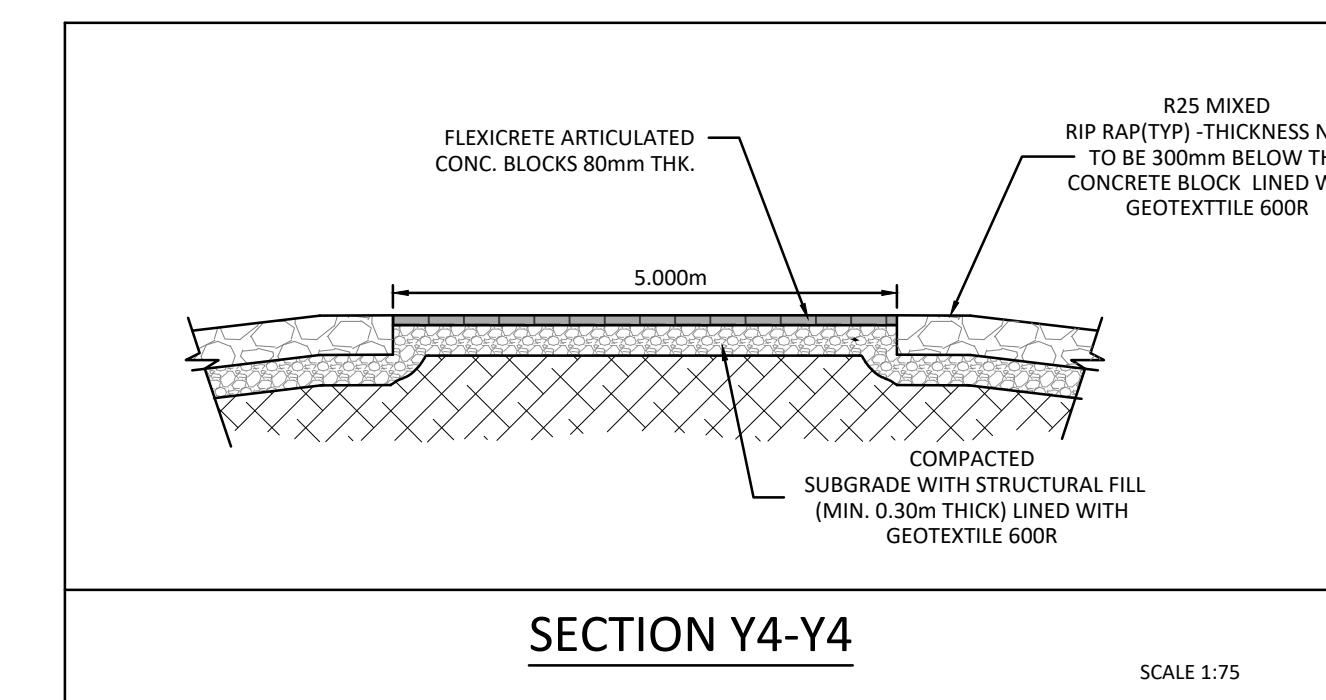

**SECTION Y4-Y4**

SCALE 1:75

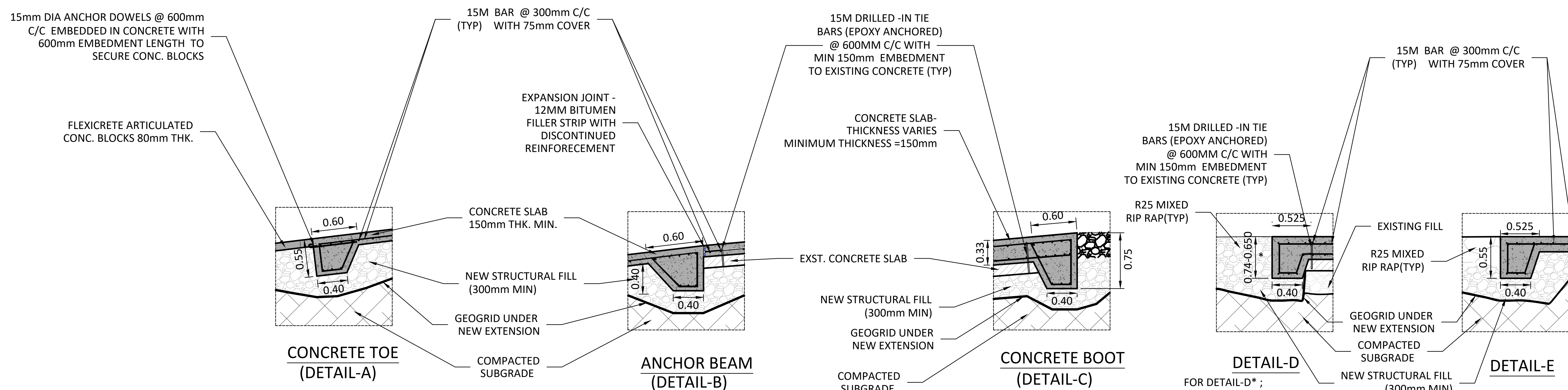

**DETAILS**

SCALE 1:25

No.	DATE	DESCRIPTION
01	25/03/2026	ISSUED FOR TENDER

Client: TOWN OF HARTLAND

Project: HARTLAND BOAT LAUNCH UPGRADES

Drawing Title: STRUCTURAL DETAILS

This drawing is the exclusive property of GLENN GROUP LTD and must be returned upon request. Reproduction in part or in whole is forbidden without the designer's permission.  
Do not scale drawings.  
The Contractor and all Sub-contractors shall verify all job site dimensions, all drawings, details & specifications. The contractor shall report any discrepancies, in writing, to GLENN GROUP LTD, prior to commencing with any work.

Date:	24.03.2026	Checked By:	DLH
Drawn By:	YUN	Scale:	
Project No.:	2508		
DWG NO.:			

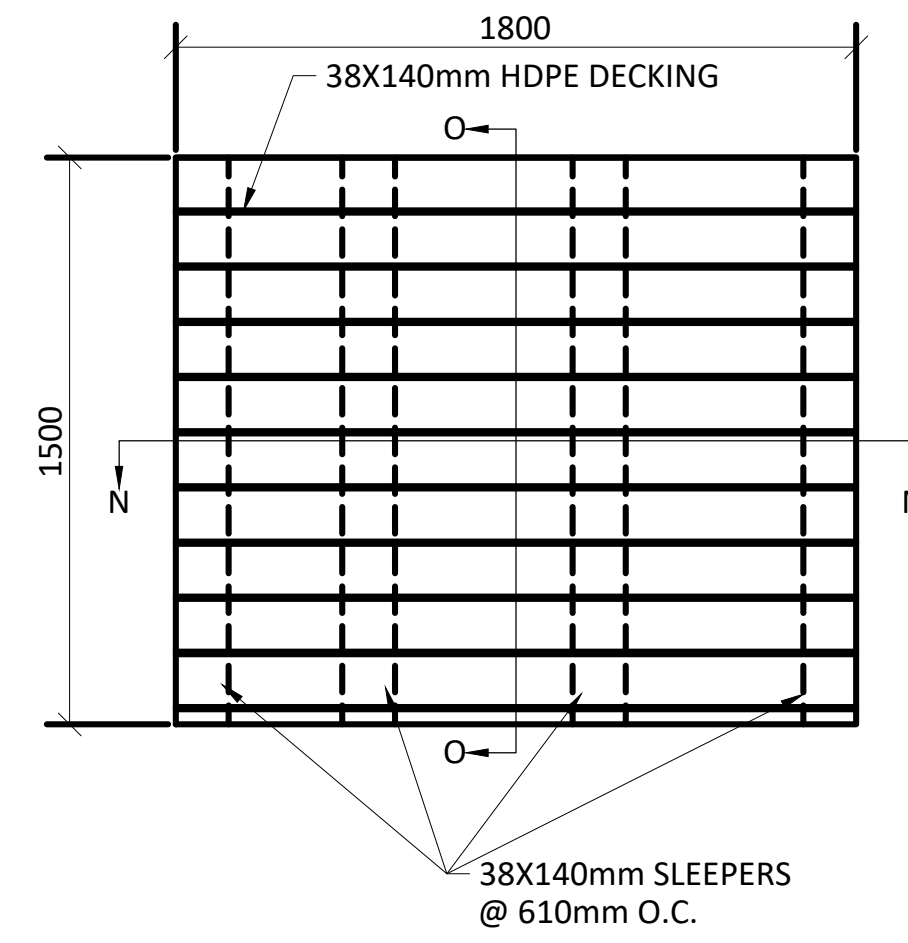

1 ABUTMENT PLAN VIEW  
S1 1:20

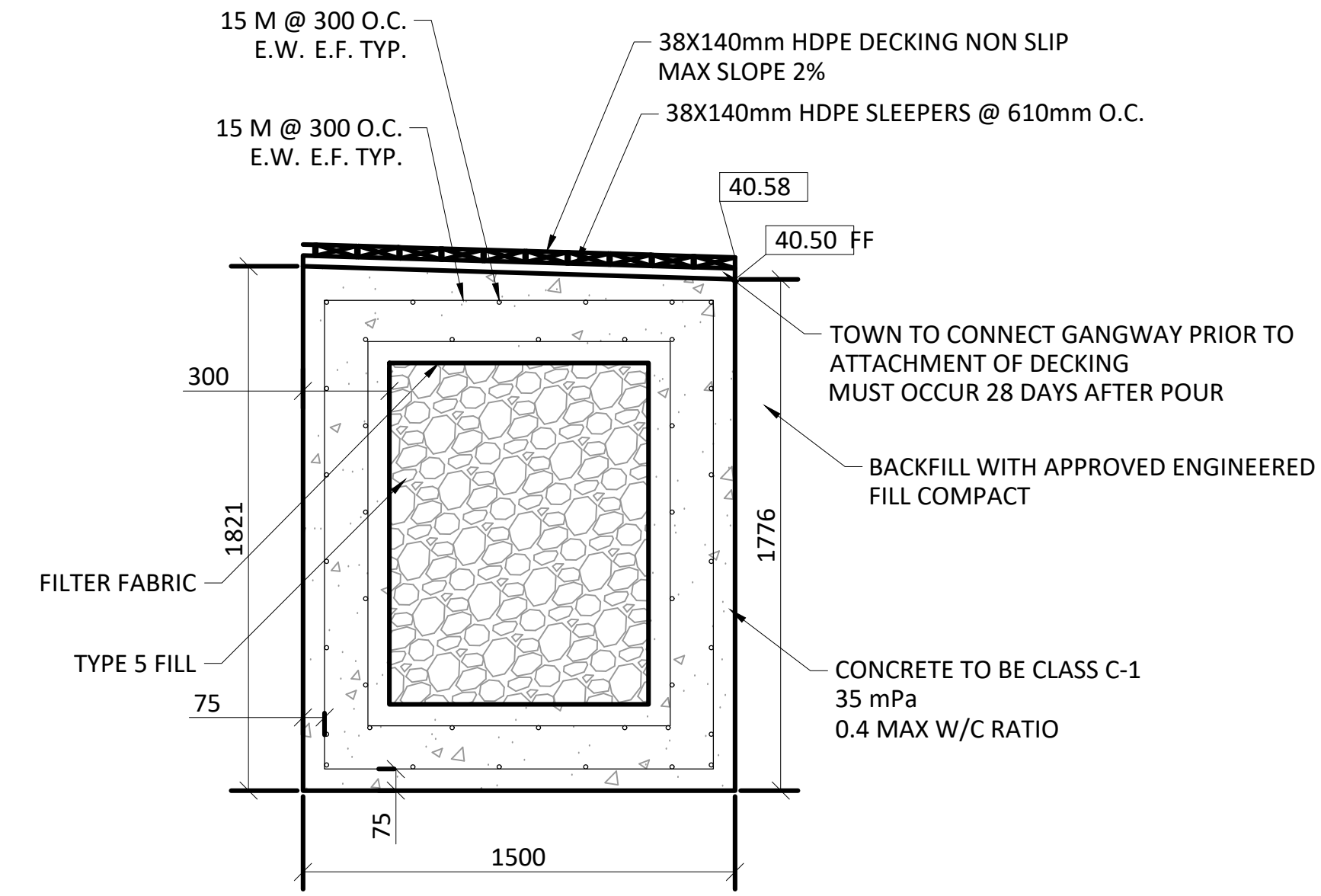

2 ABUTMENT SECTION O-O  
S1 1:20

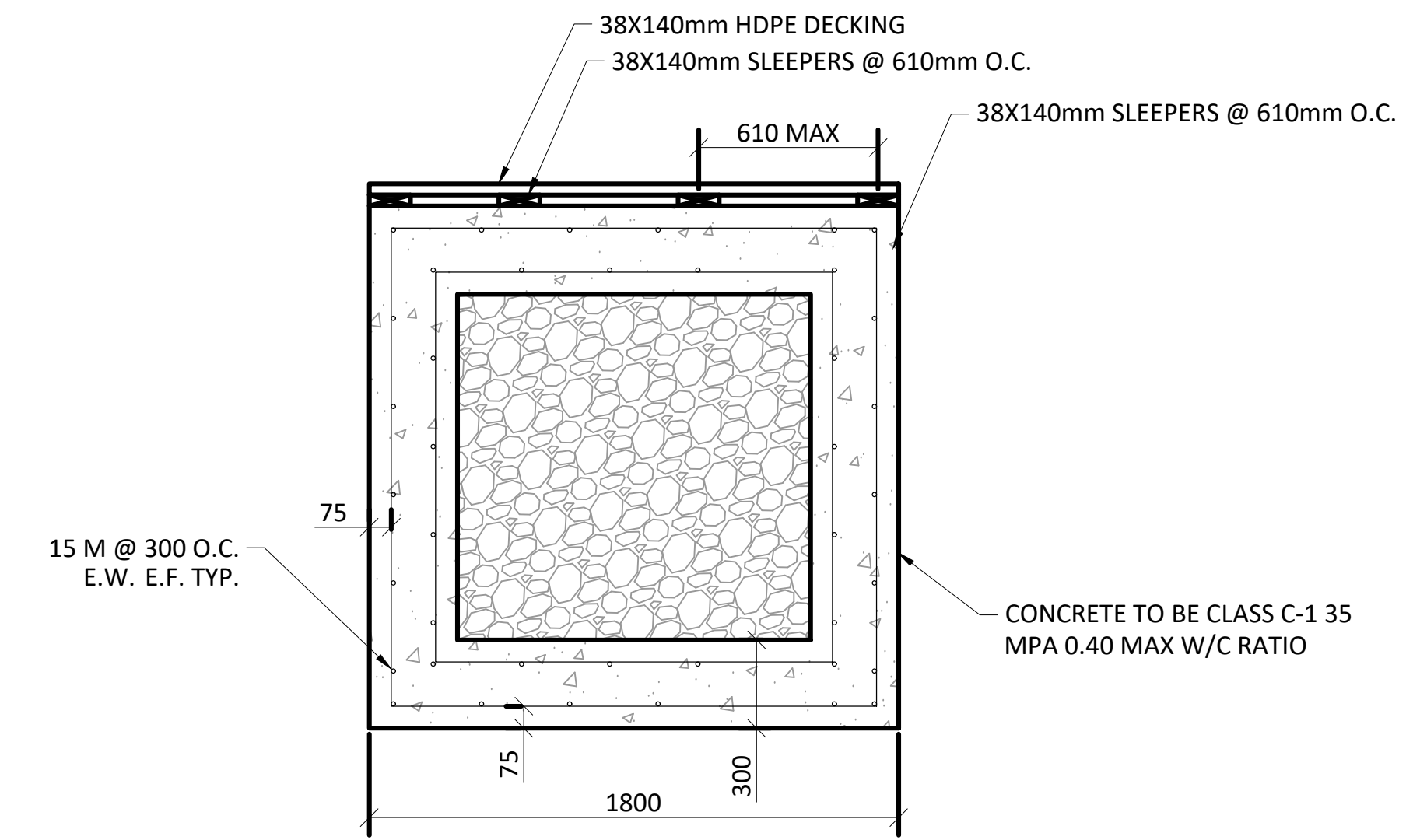

3 ABUTMENT SECTION N-N  
S1 1:20

No.	DATE	DESCRIPTION
01	25/03/2026	ISSUED FOR TENDER

Revisions:

--	--	--

Client:  
TOWN OF HARTLAND

Project:  
HARTLAND BOAT  
LAUNCH UPGRADES

Drawing Title:  
STRUCTURAL DETAILS

This drawing is the exclusive property of GLENN GROUP LTD and must be returned upon request. Reproduction in part or in whole is forbidden without the designer's permission.

Do not scale drawings.  
The Contractor and all Sub-contractors shall verify all job site dimensions, all drawings, details & specifications. The contractor shall report any discrepancies, in writing, to GLENN GROUP LTD, prior to commencing with any work.

Date: 24.03.2026	Checked By: DLH
Drawn By: YUN	Scale:
Project No.: 2508	
DWG NO.:	

#### DESIGN NOTES:

- ALL DIMENSIONS ARE IN METRES, UNLESS NOTED OTHERWISE (UNO).
- ALL DESIGN, MATERIAL, AND CONSTRUCTION SHALL CONFORM TO THE NATIONAL BUILDING CODE OF CANADA (NBC) 2020 AND ALL REFERENCED STANDARDS THEREIN, INCLUDING BUT NOT LIMITED TO CSA A23.1/A23.2 (CONCRETE MATERIALS AND METHODS) AND CSA A23.3 (DESIGN OF CONCRETE STRUCTURES).
- PROPOSED: THE EXISTING RAMP SURFACE MUST BE SCARIFIED OR HYDRO-DEMOLISHED TO A MINIMUM AMPLITUDE OF 6 MM TO SATISFY CSA A23.3-19 CL. 11.5 FOR INTENTIONALLY ROUGHENED SURFACES. FOLLOWING MECHANICAL SURFACE PREPARATION, THE EXISTING CONCRETE SHALL BE SATURATED WITH WATER AND LEFT IN A DAMP CONDITION WITH NO FREE WATER ON THE SURFACE IMMEDIATELY BEFORE PLACING NEW CONCRETE. IN ACCORDANCE WITH CSA A23.1-19 CLAUSE 7.3.1.3, A CEMENT SLURRY BONDING COAT (MAX W/C RATIO 0.50) SHALL BE MIXED TO A THICK FLOWABLE CONSISTENCY AND SCRUBBED INTO THE DAMPENED SURFACE WITH STIFF BRUSHES IMMEDIATELY PRIOR TO CONCRETE PLACEMENT. PER CSA A23.1-19 CLAUSE 7.9.4 (2A), THE TOPPING SHALL BE PLACED BEFORE THE SLURRY DRIES. EPOXY BONDING AGENTS SHALL NOT BE USED IN THIS EXTERIOR FREEZE-THAW ENVIRONMENT (CSA A23.1-19 CLAUSE 7.9.4.2 NOTE 4).
- LOCALIZED DIPS AND IRREGULARITIES (WHERE SLOPES VARY BETWEEN 8% AND 2%) SHALL BE RESTORED USING 20 MPA BONDED CONCRETE LEVELING FILL (SIKA MONOTOP 622 OR EQUIVALENT) PRIOR TO THE MAIN POUR TO ENSURE A UNIFORM SLOPE.
- FOR THE NEW EXTENSION, STRUCTURAL FILL SHALL BE PLACED AND COMPACTED AS PER NBDT SPECIFICATIONS. SUBGRADE BELOW STRUCTURAL FILL SHALL BE PROOF-ROLLED, GRADED, AND COMPACTED TO A MINIMUM OF 95% STANDARD PROCTOR DENSITY. ANY SOFT OR UNSUITABLE MATERIAL SHALL BE REMOVED AND REPLACED WITH APPROVED COMPACTED STRUCTURAL FILL. SUBGRADE SHALL BE INSPECTED AND APPROVED BY A GEOTECHNICAL ENGINEER PRIOR TO COMMENCEMENT OF NEW WORK.
- ALL STRUCTURAL FILL SHALL BE REINFORCED WITH BIAXIAL GEOGRID AND LINED WITH TERRAFIX 600R GEOTEXTILE. GEOGRID SHALL BE POLYPROPYLENE OR POLYESTER BIAXIAL TYPE (E.G., TENSAR BX OR APPROVED EQUIVALENT) WITH A MINIMUM TENSILE STRENGTH OF 30 KN/M IN BOTH DIRECTIONS.
- CONCRETE SHALL HAVE A MINIMUM COMPRESSIVE STRENGTH OF 35 MPA AT 28 DAYS. CONCRETE SHALL MEET EXPOSURE CLASS C-1 AS PER CSA A23.1-19, TABLE 2. MAXIMUM WATER-TO-CEMENTITIOUS MATERIALS RATIO: 0.40. AIR CONTENT: 5 TO 8%. MAXIMUM NOMINAL AGGREGATE SIZE: 20 MM. SLUMP: 80 +/- 30 MM. SUITABLE FOR REINFORCED CONCRETE EXPOSED TO CHLORIDES AND FREEZE-THAW CYCLES.
- ALL EXPOSED CONCRETE SURFACES SHALL HAVE A BROOM FINISH, APPLIED IN ACCORDANCE WITH CSA A23.1, TO PROVIDE A SLIP-RESISTANT SURFACE.
- ALL 15M BARS SHALL BE GRADE 400W EPOXY-COATED PER ASTM A775/A775M. FABRICATION AND HANDLING OF EPOXY-COATED BARS SHALL CONFORM TO ASTM D3963/D3963M. COATING DAMAGE SHALL BE REPAIRED IN ACCORDANCE WITH ASTM A775/A775M (CSA A23.1-19 CLAUSE 6.1.6.4). EPOXY-COATED BARS SHALL BE HANDLED AND STORED TO MINIMIZE DAMAGE TO THE COATING. DEVELOPMENT LENGTHS FOR EPOXY-COATED BARS SHALL BE INCREASED BY A FACTOR OF 1.5 PER CSA A23.3-19 CLAUSE 12.2.4. GALVANIZED REINFORCEMENT SHALL NOT BE USED IN COMBINATION WITH EPOXY-COATED REINFORCEMENT PER CSA A23.1-19 CLAUSE 6.1.4.
- A MINIMUM CLEAR COVER OF 75 MM SHALL BE MAINTAINED FOR ALL REINFORCEMENT CAST AGAINST OR PERMANENTLY EXPOSED TO EARTH, WEATHER, OR RIVER WATER, IN ACCORDANCE WITH CSA A23.1-19, CLAUSE 6.6.6 AND TABLE 17 FOR EXPOSURE CLASS C-1.
- DRILLED-IN 15M TIE BARS @ 600 MM C/C SHALL BE INSTALLED USING A HIGH-STRENGTH STRUCTURAL ADHESIVE, HILTI HIT-RE 500 V3 OR EQUIVALENT. HOLES SHALL BE DRILLED, CLEANED, AND PREPPED IN ACCORDANCE WITH THE MANUFACTURERS RECOMMENDATIONS.
- MINIMUM EMBEDMENT SHALL BE 150 MM INTO SOUND EXISTING CONCRETE, SATISFYING CSA A23.3 ANNEX D FOR ANCHOR DEVELOPMENT.
- RIP RAP CONSIST OF MIXED R-25 STONE, MUST BE PLACED AT EDGES AND THE RAMP TOE AS PER NBDT SPECIFICATIONS FOR PROTECTION AGAINST EROSION AND ICE ACTION. ALL RIP RAP SHALL BE LINED WITH TENSAR BX GEIGRID OR APPROVED EQUIVALENT AND TERRAFIX 600R GEOTEXTILE.
- PROVIDE CONTRACTION JOINTS AT A MAXIMUM SPACING OF 4.0 M IN BOTH DIRECTIONS IN APPROXIMATELY SQUARE PATTERNS, IN ACCORDANCE WITH CSA A23.1-19 CLAUSE 7.3.2.1. CONTRACTION JOINTS SHALL BE PROVIDED IN SINGLE-LAYER REINFORCEMENT AREAS ONLY. CONTRACTION JOINTS SHALL NOT BE PROVIDED IN AREAS WITH DUAL-LAYER CONTINUOUS REINFORCEMENT, AS THEY HAVE BEEN SHOWN NOT TO INDUCE CRACKING (CSA A23.1-19 CLAUSE 7.3.2.1 NOTE 4). ALL JOINTS TO BE WET DIAMOND BLADE SAW CUT TO A DEPTH OF 1/4 TO 1/3 OF THE SLAB THICKNESS, BUT NOT LESS THAN 50 MM FOR A 150 MM SLAB. SAWCUTTING SHALL COMMENCE 8 TO 24 HOURS AFTER PLACEMENT WHEN THE SURFACE HAS HARDENED SUFFICIENTLY TO RESIST RAVELLING (CSA A23.1-19 CLAUSE 7.3.2.2). SAWCUTS SHALL NOT CUT THROUGH REINFORCEMENT (CSA A23.1-19 CLAUSE 7.3.2.1 NOTE 5).
- PROVIDE A FULL-DEPTH EXPANSION JOINT AS SHOWN IN THE PLAN USING 12MM BITUMEN-IMPREGNATED FIBERBOARD SECURED AGAINST THE CURED UPHILL OVERLAY PRIOR TO CASTING THE DOWNHILL ANCHOR BEAM AND SLAB-ON-GRADE. ALL REINFORCING MESH MUST BE DISCONTINUED AT THIS INTERFACE TO PERMIT INDEPENDENT SETTLEMENT AND THERMAL MOVEMENT.
- ALL CONTROL JOINTS (C.1.) AND EXPANSION JOINT SHALL BE SEALED WITH SIKAFLEX-1A ONE-PART, NON-SAG POLYURETHANE SEALANT (OR APPROVED EQUIVALENT). INSTALLATION, SURFACE PREPARATION, AND USE OF CLOSED-CELL BACKER ROD SHALL BE ACCORDANCE WITH THE MANUFACTURER'S RECOMMENDATIONS TO ENSURE A WATERTIGHT SEAL.
- WATER LEVEL DATA WERE OBTAINED FROM DISCONTINUED ECCC HYDROMETRIC STATIONS (1973-1993) AND THE "HARTLAND BOAT LAUNCH-DESIGN FEASIBILITY ANALYSIS" REPORT DATED JUNE 27, 2025 AND ARE REFERENCED TO CGVD28 (2008) FOR DESIGN CONTEXT.

#### CONSTRUCTION SEQUENCE

- DEMOLITION & SITE PREP: REMOVE THE EXISTING CONCRETE RAMP BOUNDARIES MARKED FOR DEMOLITION.
  - SURFACE TREATMENT: SCARIFY OR HYDRO-DEMOLISH THE ENTIRE SURFACE OF THE EXISTING RAMP TO BE OVERLAID TO ENSURE A HIGH-BOND MECHANICAL PROFILE.
  - DITCH & DIP REMEDIATION: FILL LOCALIZED DIPS (WHERE SLOPES VARY BETWEEN 8% AND 2%) WITH 20 MPA BONDED CONCRETE LEVELING FILL TO ESTABLISH THE UNIFORM SUBGRADE REQUIRED FOR THE OVERLAY.
  - EXTENSION SUB-BASE: PLACE AND COMPACT 300 mm OF NEW STRUCTURAL FILL FOR THE 15.61 m LONG RAMP EXTENSION. PRIOR TO PLACEMENT OF SUB-BASE STRUCTURAL FILL, THE EXISTING SUBBASE SHALL BE INSPECTED AND APPROVED BY A GEOTECHNICAL ENGINEER.
  - ENTIRE SUB-BASE SHOULD BE PREPARED AND COMPACTED PRIOR TO PLACEMENT OF REINFORCEMENT AND FORMWORK.
  - DRILLING & DOWELING: DRILL HOLES THROUGH THE NEW LEVELING FILL (where ever applicable) AND INTO THE SOUND EXISTING CONCRETE. INSTALL 15M TIE BARS @ 600 mm C/C USING STRUCTURAL EPOXY, ENSURING A MINIMUM 125 - 150 mm EMBEDMENT INTO THE ORIGINAL SOUND SLAB.
  - FORMWORK AND REINFORCEMENT: SET FORMS FOR THE 150 MM TO 340 MM VARIABLE THICKNESS SLAB. INSTALL DUAL-LAYER 15M REBAR MAT @ 300 MM C/C WHERE SLAB THICKNESS IS 250 MM OR GREATER. INSTALL SINGLE-LAYER 15M REBAR MAT @ 300 MM C/C CENTRED IN THE SLAB WHERE THICKNESS IS LESS THAN 250 MM. MINIMUM SLAB THICKNESS FOR DUAL-LAYER REINFORCEMENT WITH 75 MM COVER BOTH FACES IS 210 MM (75 MM COVER + 16 MM BAR + 25 MM CLEAR + 16 MM BAR + 75 MM COVER).
  - EXTENSION SUB-BASE: PLACE AND COMPACT 300 mm OF NEW STRUCTURAL FILL FOR THE 15.61 m RAMP EXTENSION.
  - CONCRETE SHALL BE PROTECTED AND CURED IN ACCORDANCE WITH CSA A23.1-19, CLAUSE 7.8, CURING TYPE 2 (ADDITIONAL CURING) FOR EXPOSURE CLASS C-1. CURING SHALL CONTINUE FOR 7 DAYS AT A CONCRETE TEMPERATURE OF NOT LESS THAN 10 DEGREES C OR FOR THE TIME NECESSARY TO ATTAIN 70% OF THE SPECIFIED 28-DAY COMPRESSIVE STRENGTH, WHICHEVER IS LONGER. THE SURFACE SHALL BE KEPT CONTINUOUSLY MOIST BY PONDING, CONTINUOUS SPRINKLING, OR COVERING WITH SATURATED ABSORPTIVE BURLAP FABRIC. CURING COMPOUNDS SHALL NOT BE USED ON SURFACES THAT WILL RECEIVE BONDED OVERLAYS OR ADHESIVE ANCHOR INSTALLATIONS (CSA A23.1-19 CLAUSE 7.8.2.2 NOTE 1).
  - BLOCK INSTALLATION: INSTALL THE FLEXICRETE ARTICULATED CONCRETE BLOCKS AT THE TOE OF THE CONCRETE SLAB, SECURING THEM WITH ANCHOR DOWELS EMBEDDED IN THE CONCRETE. THE NEW Poured IN PLACE CONCRETE SLAB CANNOT BE USED FOR STAGING OR A LIFTING SURFACE UNTIL IT HAS REACHED ITS 28-DAY STRENGTH
  - SCOUR PROTECTION: PREPARE THE EDGES, INSPECT AND INSTALL GEOTEXTILE AND GEOGRID, THEN PLACE RIP RAP TO PROTECT THE STRUCTURE FROM RIVER CURRENTS AND ICE.

#### SITE VERIFICATION AND EXISTING CONDITIONS

- THE CONTRACTOR SHALL VERIFY ALL EXISTING SITE CONDITIONS IN THE FIELD PRIOR TO SUBMISSION OF THE TENDER AND PRIOR TO COMMENCEMENT OF WORK.
  - SURVEY INFORMATION PROVIDED WITHIN THE CONTRACT DOCUMENTS IS FOR GENERAL REFERENCE ONLY AND SHALL NOT BE RELIED UPON AS EXACT. THE ACCURACY, COMPLETENESS, AND SUITABILITY OF THIS INFORMATION IS NOT GUARANTEED.
  - THE CONTRACTOR SHALL CONDUCT A MANDATORY SITE VISIT TO:
    - ASSESS EXISTING GRADES, ACCESS CONDITIONS, AND CONSTRAINTS;
    - EXAMINE THE CONDITION OF THE EXISTING CONCRETE BOAT RAMP, WHICH IS KNOWN TO BE FRACTURED, IRREGULAR, AND INCONSISTENT;
    - IDENTIFY ANY CONDITIONS THAT MAY IMPACT CONSTRUCTION METHODS, SEQUENCING, OR PRICING.
  - BY SUBMISSION OF A TENDER, THE CONTRACTOR SHALL BE DEEMED TO HAVE SATISFIED THEMSELVES AS TO THE FULL EXTENT OF EXISTING SITE CONDITIONS AND LIMITATIONS AFFECTING THE WORK. NO CLAIMS FOR EXTRAS WILL BE CONSIDERED ARISING FROM CONDITIONS THAT COULD REASONABLY HAVE BEEN OBSERVED DURING A SITE VISIT.
  - THE CONTRACTOR IS NOT REQUIRED TO UNDERTAKE A FORMAL SURVEY AS PART OF THE TENDER. VERIFICATION OF SITE CONDITIONS SHALL BE BASED ON VISUAL INSPECTION AND REASONABLE FIELD ASSESSMENT ONLY.
  - FOLLOWING CONTRACT AWARD, THE CONTRACTOR SHALL VERIFY CRITICAL DIMENSIONS AND LAYOUT REQUIRED FOR CONSTRUCTION AND SHALL NOTIFY THE CONSULTANT OF ANY DISCREPANCIES PRIOR TO PROCEEDING WITH THE WORK.

#### FLEXICRETE ARTICULATED BLOCK SPECIFICATIONS

- FLEXICRETE ARTICULATED CONCRETE BLOCKS: TERRAFIX FLEXICRETE, 400 MM X 400 MM X 80 MM THICK, 30 MPA MINIMUM COMPRESSIVE STRENGTH, CONNECTED BY GALVANIZED WIRE MESH REINFORCEMENT (203 MM C/C, 8/8 GAUGE), MANUFACTURED IN ACCORDANCE WITH CSA A23.4-16. INDIVIDUAL BLOCK WEIGHT: 27 KG. PANEL WEIGHT: 168 KG/M<sup>2</sup>. BLOCKS SHALL BE INSTALLED OVER A PREPARED BED CONSISTING OF (FROM TOP TO BOTTOM): 150 MM MINIMUM OF 19 TO 50 MM CLEAR, ANGULAR, CRUSHED STONE DRAINAGE MEDIUM, OVER TERRAFIX 600R NON-WOVEN GEOTEXTILE FILTER FABRIC, OVER COMPACTED GRANULAR SUB-BASE. THE PREPARED SURFACE SHALL BE SMOOTH, FREE OF ALL ROCKS, STICKS, ROOTS, OR OTHER PROTRUSIONS, AND SHALL PROVIDE A FIRM AND UNYIELDING FOUNDATION WITH NO SHARP OR ABRUPT BREAKS IN GRADE. BLOCKS SHALL NOT BE PLACED DIRECTLY ON UNIMPROVED RIVER BED. TOE BLOCKS (MINIMUM 2 ROWS) SHALL BE EMBEDDED IN A TRENCH MINIMUM 305 MM DEEP AND BACKFILLED WITH 30 MPA CONCRETE, PER TERRAFIX SPILLWAY AND BOAT LAUNCH RAMP TERMINATION TRENCH DETAIL (2017).

- ANCHOR DOWELS FOR FLEXICRETE BLOCK CONNECTION: 15M DEFORMED REINFORCING BARS, GRADE 400W, EPOXY-COATED PER ASTM A775/A775M, AT 600 MM CENTRE-TO-CENTRE. DOWELS SHALL BE CAST IN PLACE DURING THE CONCRETE POUR WITH 600 MM HORIZONTAL EMBEDMENT INTO THE RAMP SLAB, PROJECTING HORIZONTALLY FROM THE TOE FACE TO ENGAGE THE FLEXICRETE BLOCKS. DEVELOPMENT LENGTH SHALL SATISFY CSA A23.3-19 CLAUSE 12.2, INCLUDING THE 1.5X MODIFICATION FACTOR FOR EPOXY-COATED BARS PER CLAUSE 12.2.4.

#### ENVIRONMENTAL PROTECTION REQUIREMENTS

- GENERAL:
  - CONDUCT ALL WORK IN A MANNER THAT PREVENTS EROSION, SEDIMENTATION, AND ENVIRONMENTAL DAMAGE.
  - LIMIT DISTURBANCE TO THE MINIMUM AREA REQUIRED TO COMPLETE THE WORK.
  - PROTECT ALL ADJACENT VEGETATION, WATER BODIES, AND ENVIRONMENTALLY SENSITIVE AREAS.
- EROSION AND SEDIMENT CONTROL:
  - IMPLEMENT EROSION AND SEDIMENT CONTROL MEASURES PRIOR TO COMMENCEMENT OF ANY EARTHWORKS.
  - MAINTAIN ALL CONTROLS IN EFFECTIVE WORKING ORDER FOR THE DURATION OF THE WORK.
  - PREVENT THE RELEASE OF SEDIMENT-LADEN WATER INTO ANY WATERCOURSE, DITCH, OR DRAINAGE SYSTEM.
  - INSPECT CONTROLS DAILY AND AFTER RAINFALL EVENTS; REPAIR IMMEDIATELY AS REQUIRED.
  - REMOVE ACCUMULATED SEDIMENT FROM CONTROL MEASURES AND DISPOSE OF IN AN APPROVED LOCATION.
- WATERSHED PROTECTION:
  - ENSURE THAT NO MEASURABLE EROSION OCCURS AS A RESULT OF CONSTRUCTION ACTIVITIES.
  - STABILIZE EXPOSED SOILS IMMEDIATELY USING APPROPRIATE METHODS (E.G., SEEDING, MATTING, STONE).
  - PREVENT CONCENTRATION OF RUNOFF THAT COULD LEAD TO DOWNSTREAM EROSION OR SEDIMENT TRANSPORT.
- WORK IN AND AROUND WATER
  - GENERAL:
  - ALL IN-WATER WORK SHALL BE CAREFULLY PLANNED AND EXECUTED TO MINIMIZE DISTURBANCE TO THE WATERBODY.
  - LIMIT THE DURATION AND EXTENT OF IN-WATER WORK TO THE MINIMUM REQUIRED.
- EQUIPMENT USE:
  - HEAVY EQUIPMENT OPERATING NEAR OR WITHIN WATER SHALL BE IN GOOD WORKING ORDER AND FREE OF LEAKS.
  - INSPECT ALL EQUIPMENT DAILY FOR FUEL, OIL, OR HYDRAULIC LEAKS.
  - REFUELING AND MAINTENANCE SHALL NOT OCCUR WITHIN 30 M OF ANY WATERBODY.
  - USE BIODEGRADABLE HYDRAULIC FLUIDS WHERE PRACTICABLE.
- SEDIMENT CONTROL IN WATER:
  - ENSURE THAT SEDIMENT MIGRATION BEYOND THE WORK AREA DOES NOT OCCUR.
  - SUSPEND WORK IF VISIBLE SEDIMENT PLUMES EXTEND BEYOND CONTROL LIMITS.
  - ACCESS AND DISTURBANCE:
  - MINIMIZE THE NUMBER OF ACCESS POINTS TO THE WATER.
  - AVOID UNNECESSARY DISTURBANCE OF THE SHORELINE AND BED OF THE WATERCOURSE.
  - RESTORE ALL DISTURBED AREAS TO PRE-CONSTRUCTION CONDITION OR BETTER.
- POLLUTION PREVENTION:
  - SPILL PREVENTION:
  - PROVIDE SPILL KITS ON SITE AT ALL TIMES.
  - TRAIN PERSONNEL IN SPILL RESPONSE PROCEDURES.
  - IN THE EVENT OF A SPILL, IMMEDIATELY CONTAIN, REPORT, AND REMEDIATE.
- MATERIAL HANDLING:
  - STORE FUELS, LUBRICANTS, AND HAZARDOUS MATERIALS IN DESIGNATED AREAS AWAY FROM WATERCOURSES.
  - PROVIDE SECONDARY CONTAINMENT FOR ALL FUEL STORAGE.
  - MONITORING AND COMPLIANCE
  - THE CONTRACTOR SHALL MONITOR ENVIRONMENTAL CONDITIONS CONTINUOUSLY DURING CONSTRUCTION.
  - ANY NON-COMPLIANCE, ENVIRONMENTAL DAMAGE, OR RELEASE OF SEDIMENT OR CONTAMINANTS SHALL BE IMMEDIATELY REPORTED TO THE CONSULTANT AND CORRECTED AT NO ADDITIONAL COST TO THE OWNER.

FAILURE TO MAINTAIN ADEQUATE ENVIRONMENTAL PROTECTION MEASURES MAY RESULT IN SUSPENSION OF WORK.



No.	DATE	Description
01	25/03/2026	ISSUED FOR TENDER

Revisions:

No.	DATE	Description
-----	------	-------------

Client:  
**TOWN OF HARTLAND**

Project:  
**HARTLAND BOAT LAUNCH UPGRADES**

Drawing Title:  
**DESIGN NOTES**

This drawing is the exclusive property of GLENN GROUP LTD and must be returned upon request. Reproduction in part or in whole is forbidden without the designer's permission.

Do not scale drawings.

The Contractor and all Sub-contractors shall verify all job site dimensions, all drawings, details & specifications. The contractor shall report any discrepancies, in writing, to GLENN GROUP LTD, prior to commencing with any work.

Date:  
24.03.2026

Drawn By: YUN  
Project No.: 2508  
DWG No.:

Checked By: DLH  
Scale: